

**CANTEEN STORES DEPARTMENT**  
 Adelphi, 119 M.K.Road  
 Mumbai - 400 020.  
 Ph no. 022-2203 7120  
 E-Mail : [agmew@csdindia.gov.in](mailto:agmew@csdindia.gov.in)

Name of Work	Repair to single & married accommodation at Officers Institute at CSD Estate Ghatkopar
Type of contract	The tender shall be based on specifications/ drawing placed in Schedule 'A' (list of items of work) to be priced by tender. The Tenders are required to quote rates against items of Schedule `A`.
Cost of tender documents	Rs. 500/- in the shape of DD/Bankers Cheque from any schedule Bank in favor of CSD PUBLIC FUND A/C (MAIN).
Website/portal address	<a href="mailto:agmew@csdindia.gov.in">agmew@csdindia.gov.in</a>
Earnest Money	5% of the cost of the tender/ quoted amount. (in cheque)
Tender Issuing Authority	AGM (E&W) CSD, Ho.
Executing agency	E&W Branch CSD, HO. Mumbai

**\* Information and details**

- (a) Date of Publish of tender/bid :- 11 Nov 2024  
 (b) Tender/ bid submission start date :- 15 Nov 2024  
 (c) Last date of tender/ bid submission :- 02 Dec 2024 (at 15.00 hrs)  
 (d) Date of tender/ bid opening :- 05 Dec 2024 (at 15.10 hrs)

**NOTE:**

1. Contractors will required to upload/ submit following documents for checking eligibility :

- (a) Application for tender on firm's letter head.
- (b) DD/ Bankers cheque toward 5% cost of tender and Earnest Money Deposit (EMD) instrument.
- (c) Copy of valid passport / Adhar card of proprietor / each Director.
- (d) Details of works being executed in Govt. Agencies or any reputed firm, if any.
- (e) Any other documents required as described in this Appendix.

2. Contractor will not be allowed to execute the work by subletting or through power of attorney to a third party / another firm on his behalf. However a contractor can executed the work through power of attorney to sons / daughters / spouse of Proprietor / Partner / Director and firm's own employees, director, project manager provided they are not having a separate enlisted firm in their name as Proprietor / Partner / Director.

3. **GST REGISTRATION (AMENDED UP TO DATE) NUMBER**

- (a) Keeping in view the applicability of GST on all contracts. It is mandatory for the Contractors to upload their GST Registration Number along with the T<sup>m</sup>bid. This will be one of the criteria for qualifying in "T<sup>m</sup>bid. Contractor, who does not upload GST Registration Number, shall be disqualified in the T<sup>m</sup>bid evaluation and his financial bid shall not be opened.
- (b) The above documents in pdf format shall be uploaded in Cover No 1 of the bid.

4. The tenderers/bidders are advised to visit the site of work by making prior appointment with E&W Competent authority who is also the executing agency of work (See appendix 'A'). The tenderers/bidders are deemed to have full knowledge of all relevant documents, samples, site etc, whether they have inspected them or not.
5. WATER CONDITIONS (31 OF IAFW-2249 GENERAL CONDITIONS OF CONTRACTS)\*  
Water will be supplied by the CSD on payment @ Rs.3.75 per every thousand rupees (Rs.1000/-) worth of work done at contracts rates.
6. 5% of the final bill amount & EMD will be kept by the Department as Security Deposit / Performance security till the end of the maintenance period (One year from the date of final bill payment) and the amount will be released thereafter. The firm will attend to all repair works at free of cost during the maintenance liability period.
7. If the Contractor fails to complete the work and clear the site on or before the date fixed for completion, he shall be liable to pay compensation as per CSD procedure.
8. In all matters, the AGM/MGR./SUPT. - (E&W) is entitled to appraise the quality and payment.

SIGNATURE OF CONTRACTOR  
Dated: 06 Nov 2024

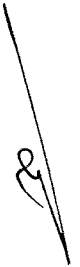
  
AGM (E&W) CSD  
ACCEPTING OFFICER.

## INSTRUCTIONS ON FILLING AND SUBMISSION OF TENDER

### 1. EARNEST MONEY DEPOSIT (EMD) :

All contractor(s) shall submit Earnest Money Deposit as detailed in Notice of Tender in one of the following forms, along with their tender/bid:-  
\* EMD

(a) Deposit at Call Receipt from a Scheduled Bank in favor of CSD PUBLIC FUND A/C (MAIN).

NOTES. NON-SUBMISSION OF EARNEST MONEY DEPOSIT (EMD) (scanned copy along with Technical Bid & hard copy before the date & time fixed for opening of BOQ) WILL RENDER THE BID DISQUALIFIED FOR OPENING OF COVER II (FINANCE BID).

### 2. REVOCATION/ REVISION OF OFFER UPWARD OFFERING VOLUNTARY REDUCTION AFTER OPENING OF FINANCIAL BIDS BY LOWEST BIDDER :

In the event of lowest tenderer/bidder revoking his offer or revising his rates upward, offering voluntary reduction, after closing of bid submission date & time, his offer will be treated as revoked and the Earnest Money deposited by him shall be forfeited. In addition, bids of such tenderer/bidder and his related firm shall not be opened in second call or subsequent calls. Reduction offered by the tenderer/bidder on the freak high rates referred for review shall not be treated as voluntary reduction.

### 3. THEFT/DAMAGE TO INSTALLATIONS :

In case of any theft, damage to installations/defence property, due to negligence, intentions on the part of the individuals employed by the Service Provider, a board of officers appointed by the Accepting Officer to investigate the matter and pin point the responsibility. If the board of officers identify the persons employed by the Service Provider, he (the Service Provider) is liable to pay such compensation as decided by the Accepting Officer. The decision of the Accepting Officer in this regard shall be final and Service Provider shall have no claim on this account.

### 4. PAYMENT T&C'D :

The Payment will be released on the firm A/c submitted by Contractor only after satisfactory work completed by contractor, within time scheduled & T&C'D & specification mentioned in Tender & directions given by Competent Authority of E&W, CSD.

\*These instructions shall form part of the contract documents. Signature of Contractor for Accepting Officer,

  
AGM  
(E&W) CSD  
ACCEPTING OFFICER.

Sr No	Description of Item	Qty (sqft)	Rate	Amount	Remarks
1	<b>Dismantling wrought iron or mild steel work</b> of any description not otherwise provided for	100			
2	<b>Framed work such as grills, gratings, etc.</b> with ends of bars shouldered and/or riveted, or forged into spikes; framed guard bars; barred iron doors; ladders; framed balusters; walk ways; railings; framework of water tanks and similar work conforming to Fe.290.Gde-E-165	300			
3	<b>S&amp;F ceiling boards</b> (fibre, pulp, insulation, etc.) or insulation boards/slabs/ blankets, any thickness, including cover fillets (PVC Pannel 8 - 10 mm)	1315			
4	<b>M/L PVC insulation panels with EPS stuck</b> to 1mm plain PVC sheet suitably placed in false ceiling grid made of Aluminium/G.I./M.S.	130			
5	<b>Anti termite tretment</b> Of voids in masonry using chemical emulsion one litre per hole, at 300mm intervals including drilling holes at 45 degree and replugging them with cement mortar 1:2 (1 cement : 2 coarse sand)	500 rft			
6	<b>M/L Solid PVC Door Frame</b> made out of 5mm plain colour PVC sheet reinforced with M.S./ aluminium Square tube, suppling & fixing in opening as per specification & drawing	189			
7	<b>M/L factory made aluminium anodised</b> any colour selected Engg in Charge, <b>three track panels sliding window shutters</b> with S S wire mesh (02 glazed & 01 wire mesh panels) incl all fittings & accessories etc.	200			
8	<b>S&amp;F of curtain rod/ blinds</b> in reapiers Harrison rails, mild steel, chromium plated with fixing brackets, stops, rollers etc	06 nos			
9	<b>S&amp;F Granite (of any type) tiles</b> 20mm thick machine cut, bedded and jointed with grey cement slurry(Screed bed or bedding layer of mortar 15 mm thick for laying floor finishes) and pointed with white cement with admixture of pigment to match the shade of granite stone including grinding and polishing complete	115			
10	<b>S&amp;F 18 mm thick marine plyboard laminate</b> of any colour with high glossy acrylic sheet of 3 mm thick grade as per IS 14587 for frame & shutter for kitchen cabinate as per specified & directed	108			

11	S&F stainless steel 304 electro polished forcorrosin resistance <b>modular Cup &amp; sasur holder/ basket</b> incl telescopic drawer channel. (Make : Godrej Kitchen fittings) as appendix A	04 nos			
12	S&F stainless steel 304 electro polished forcorrosin resistance <b>modular Cutlary holder/ basket</b> incl telescopic drawer channel. (Make : Godrej Kitchen fittings) <u>as appendix B</u>	04 nos			
14	S&F <b>globe or gate valves</b> , with iron wheel head, screwed both ends for iron pipe and fixed (2" - 4")	10 nos			
15	S&F <b>Stop valves</b> , cast copper alloy, screwed down, high pressure, with crutch or butterfly handle, screwed both ends for iron pipe or for unions and fixed (2" - 4")	20 nos			
17	S&F <b>ACP sheet</b> for doors incl all fittings as directed	260			
19	S&F <b>Health foucet</b> incl PVC pipe of 1.5 m long for EWC with all accessories & required fittings & connections to the line. (Make: Jagure model ALD-577)	02 each			
20	S&F <b>wall hung WC</b> with all accessories & required fittings & connections to the line. (Make: Jagure model FLS-WHT-5353PPZ)	02 each			
21	S&F <b>shower incl pipe</b> fixed with all accessories & required fittings & connections to the line. (Make: Jagure model)	02 each			
22	S&F <b>sinks made of stainless steel</b> 1mm thick kitchen or laboratory with plugs, washers and wastes; including bedding in cement mortar on to dwarf wall or including fixing cantilever brackets and connecting union to pipe, overall size 495mm x 420mm bowl size 410mm x 330mm x 160mm	02 each			
23	S&F countertop <b>wash basin</b> with all accessories & required fittings & connections to the line. (Make: Jagure model CNS-WHT-903)	04 each			
24	S&F <b>Low density polyethylene (LDPE)</b> pipes of pressure rating 6 kgf/sq. cm	04 each			
25	M&L <b>Taking up or down steel tubing and connections</b> , including cleaning for refixing or removal to store	50 RM			
26	Taking out Tubes, 'light grade' galvanised, with all fitting and fixed complete to walls and ceilings or laid in floors	170 RM			

27	Supplying & fixing to walls/chases/ceilings or laying in floors PolyethyleneAluminium Ployethylene (PE-AL-PE) composite pressure pipes including all Crimp type internal sealing Plansticmetal Composite fittings (such as elbows, tees, reducers, couplers, short pieces, connectors, etc.) and hooks (in case of concealed pipe work)/ clamps (in case of exposed pipe work) complete.	50 RM			
28	S&F Cast iron <b>Nahani trap</b> floor trap, with grating including jointing to waste pipe fixed in cement concrete (120 m)	02 each			
29	<b>Non - skid Ceramic tiles</b> 7 to 8 mm thick (square/ rectangular) area of each tile exceeding 0.11 sqm but not exceeding 0.18 sqm, in floors etc. set and jointed in neat cement slurry and pointed in white or coloured cement to match & 1Rendering 10mm thick on fair faces of brick work or concrete surfaces	500			
30	Removing old lime wash (if any), hacking for key, raking out joints of old brick work or stone work built in lime or mud mortar; not previously plastered; and scrubbing & Dubbing out average 10mm thick on irregular face of walls (when specifically ordered in writing)	5630			
31	M&L <b>Preparing surfaces plastered or unplastered Chalk whitening</b> , on plastered surfaces, preparatory to distempering, distemper oil emulsion. (02 coats)	1510			
32	Concrete of any description and in any position not otherwise specifically provided	195			
33	One <b>3 pin socket outlet. 15 amps</b> , independent, with cables 4 sq. mm size	5 points			
34	S&F <b>LED lights</b> as per directions of engg in charge (22 w)	20 points			
35	S&F <b>ceiling fan</b> , location as per directions of engg in charge	04 nos			
36	S&F <b>safety doors</b> with painting & all accessories (wood + ms)	90			
		Amount			
		Total			
		GST 18%			
		<b>Grand total</b>			

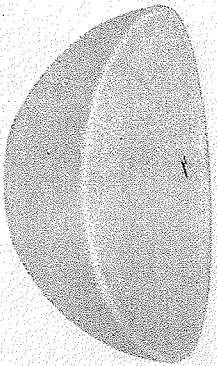

**CNS-WHT-905**  
Table Top Basin.  
Size: 425x340x175 mm

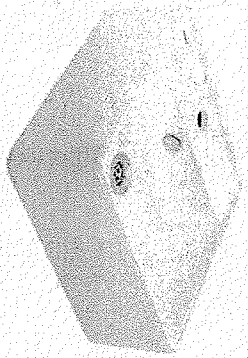
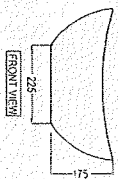
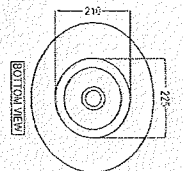
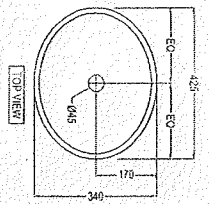

**CNS-WHT-905**  
Table Top Basin.  
Size: 420 x 420 x 155 mm

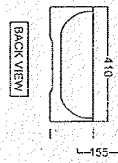
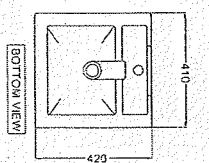
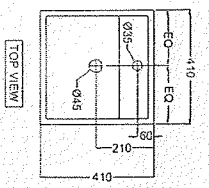

**CNS-WHT-701**  
Under Counter Basin with Fixing  
Accessories.  
Size: 435x370x205 mm.  
Shape: Rectangular

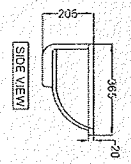
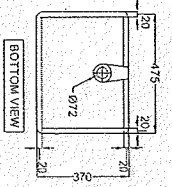
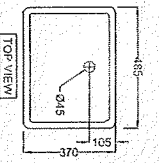

**CNS-WHT-705**  
Under Counter Basin with Fixing  
Accessories.  
Size: 605x450x200 mm.  
Shape: Oval

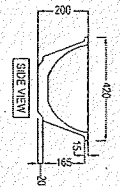
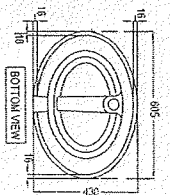
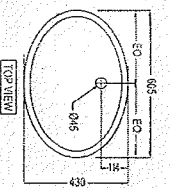

# Florentine

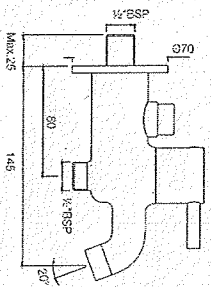
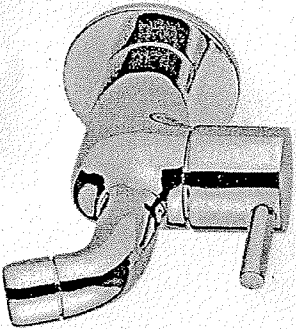

**FLR-5047N**

Bid. Cock (Straight Line Model) With Wall Flange

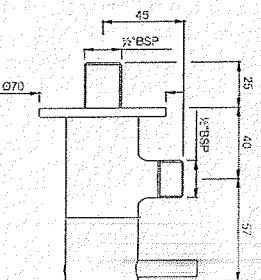
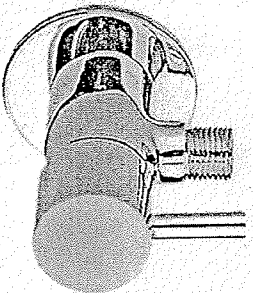

**FLR-5053N**

Angular Stop Cock With Wall Flange

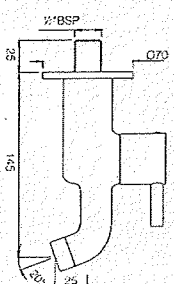
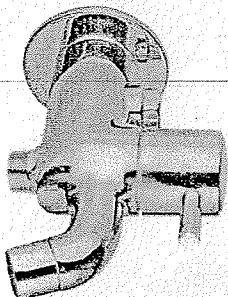

**FLR-5041N**

2 Way Bid. Cock With Wall Flange

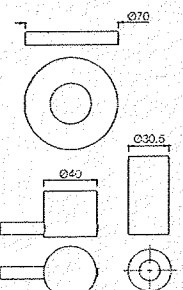
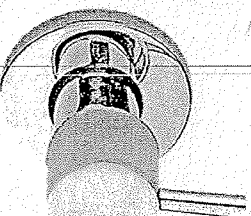

**FLR-5083NK**

Exposed Part Kit of Concealed Stop Cock & Flush Cock with Fitting Sleeve, Operating Lever & Adjustable Wall Flange with Seal (compatible with ALD-083, ALD-089 & ALD-081)

Aquamax Thermostatic Mixer

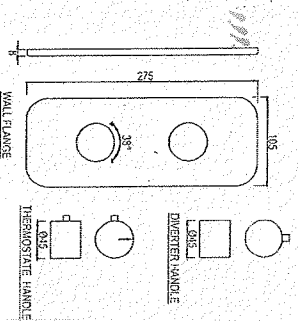

**FLR-5661K**

Aquamax Exposed Part Kit of Thermostatic Shower Mixer (Suitable for ALD-661)

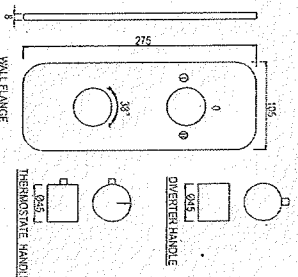

**FLR-5681K**

Aquamax Exposed Part Kit of Thermostatic Shower Mixer with 2-way diverter (Suitable for ALD-681)



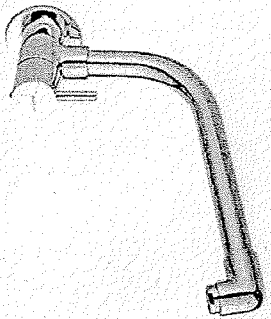

**FLR-5347SD**

Sink Cock with Extended Swinging Spout (Wall Mounted Model) With Wall Flange

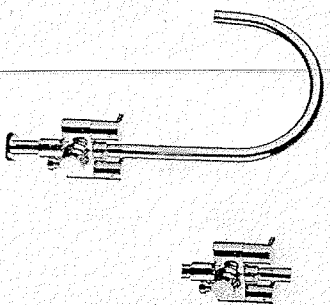
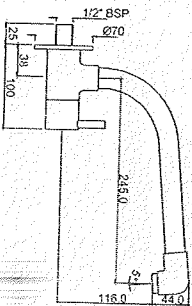

**FLR-5355N**

Sink Cock with Provision for Connection to RO from rear side & Swinging Spout

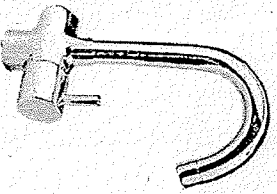
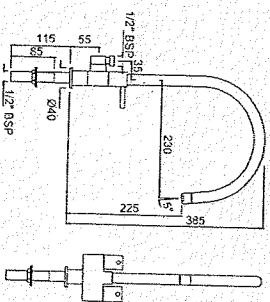

**FLR-5357N**

Sink Cock with Regular Swinging Spout (Table Mounted Model)

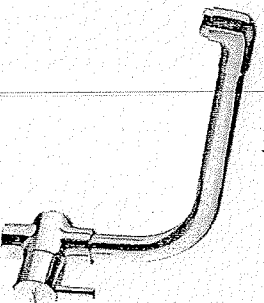
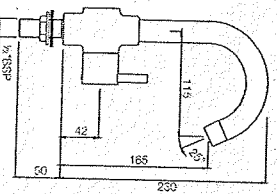

**FLR-5357SD**

Sink Cock with Extended Swinging Spout (Table Mounted Model)

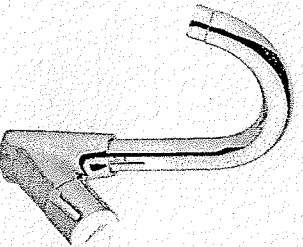
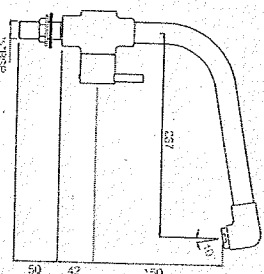

**FLR-5359N**

Sink Cock (Table Mounted) with Angular Knob

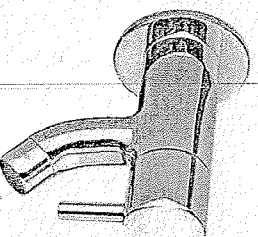
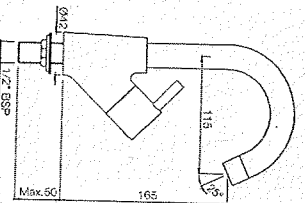

**FLR-5037N**

Bib Cock (Angular Shape) with Wall Flange

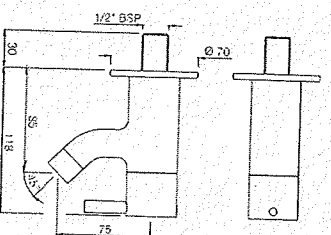

4/1/20

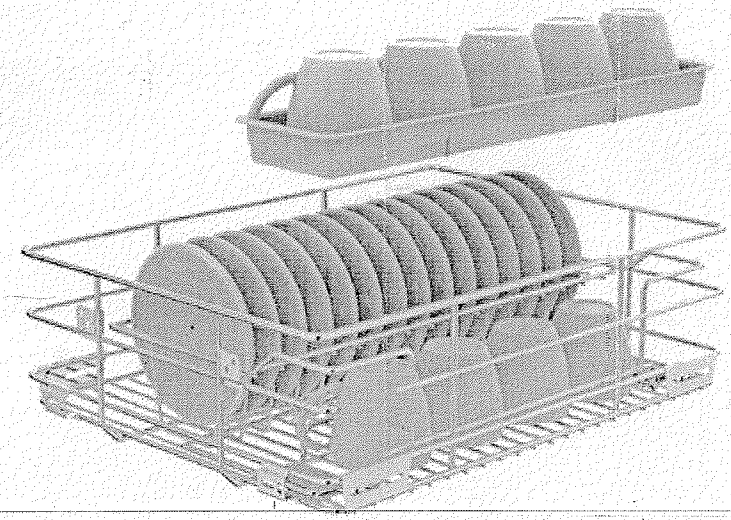
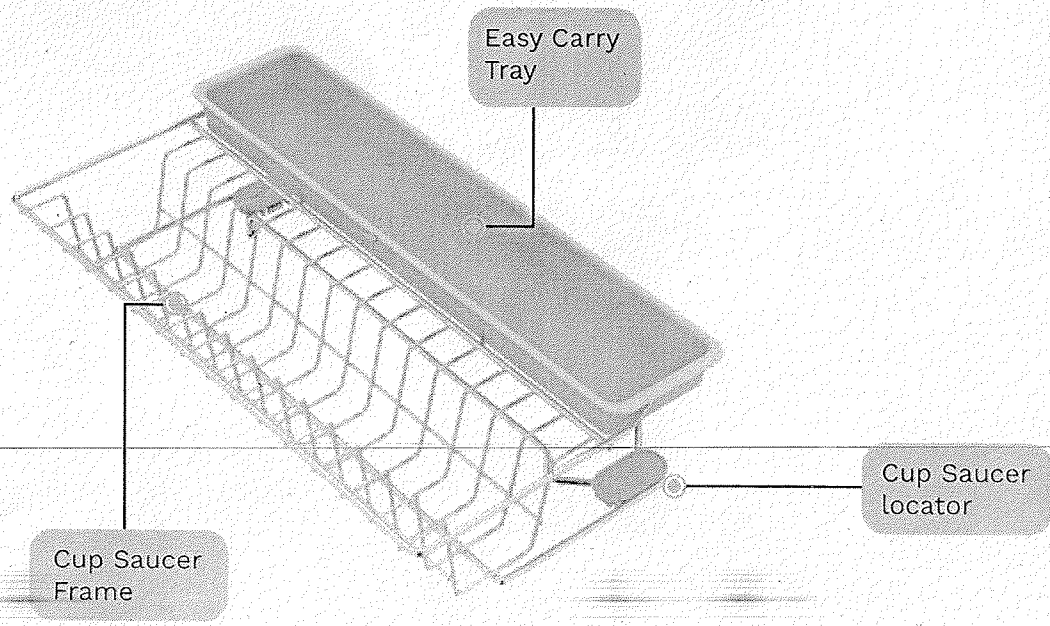

The additional easy-to-carry tray utilises the vertical storage space, doubling the cup storage capacity.

The Cup & Saucer Organiser consists of 1 wire frame, 1 easy carry tray and 2 locators. This set is suitable for 38cm, 43cm, 48cm and 53cm drawer sizes.

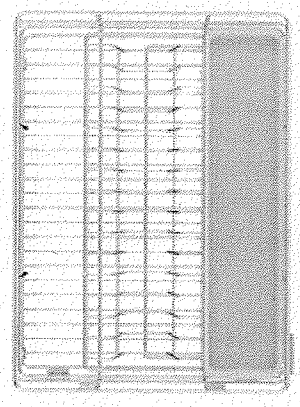

38cm  
Drawer | 4270

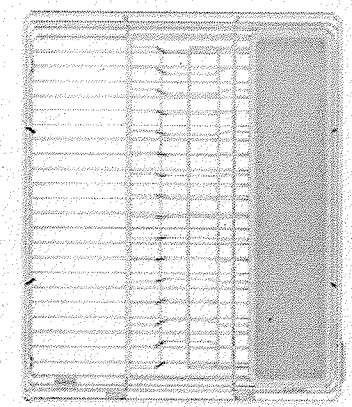

43cm  
Drawer | 4270

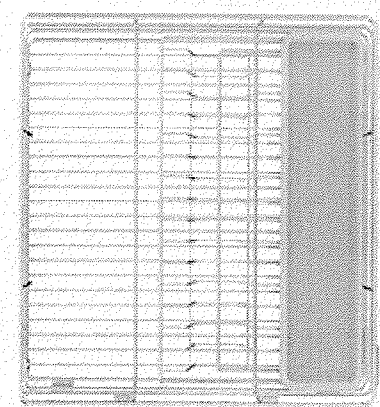

48cm  
Drawer | 4270

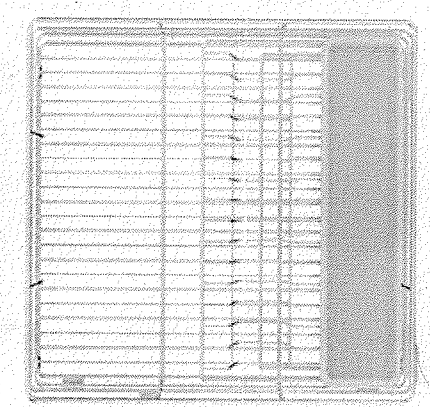

53cm  
Drawer | 4270

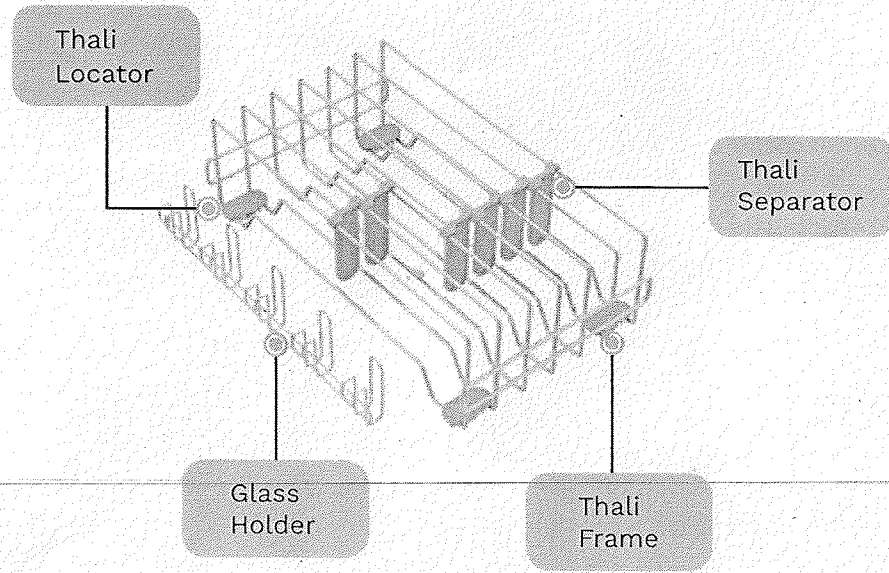

Wasted space.

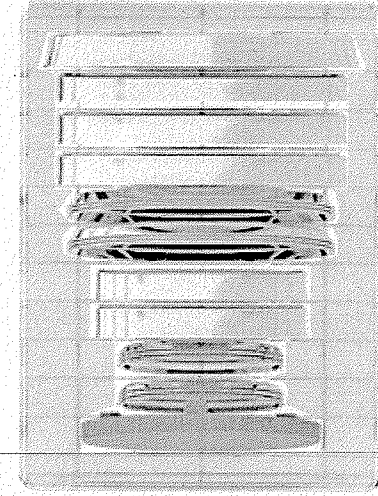

Currently thalis and plates are stored this way, leaving space unutilised.

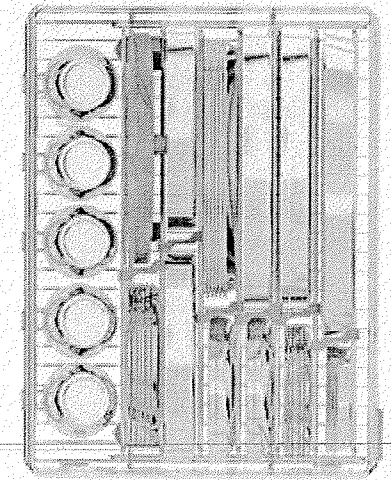

SKIDO Thali Organiser stores thalis efficiently and ensures more space utility.

Thali Organiser consists of 1 wire frame, 6 adjustable thali separators and 4 locators. This set is available in two sizes **15** for 38cm & 43cm drawers and **19** for 48cm & 53cm drawers.

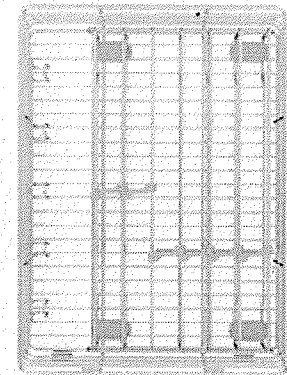

38cm  
Drawer | 4275

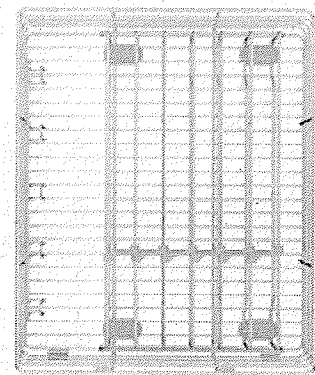

43cm  
Drawer | 4275

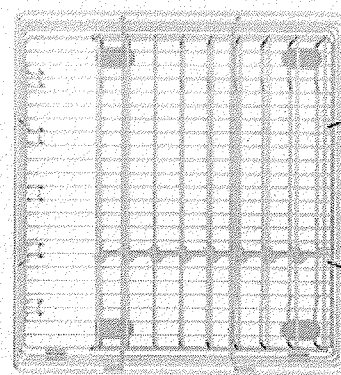

48cm  
Drawer | 4276

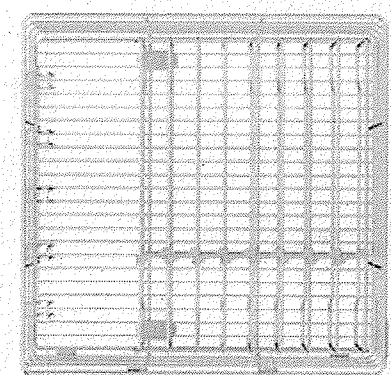

53cm  
Drawer | 4276

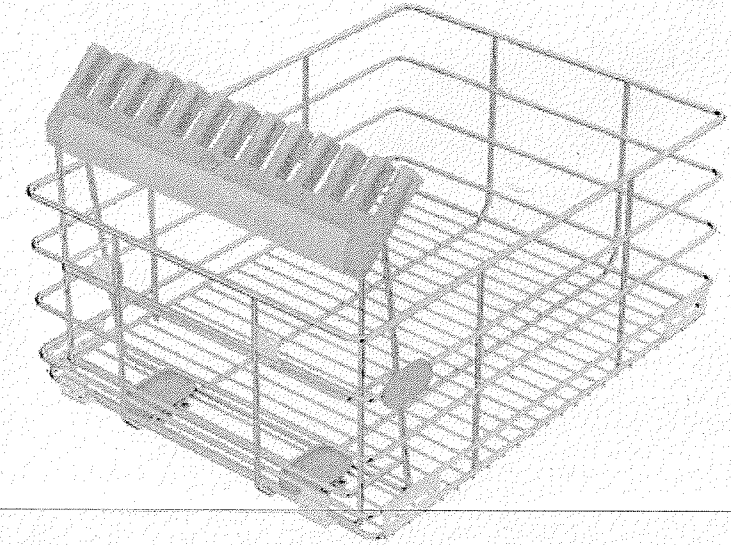
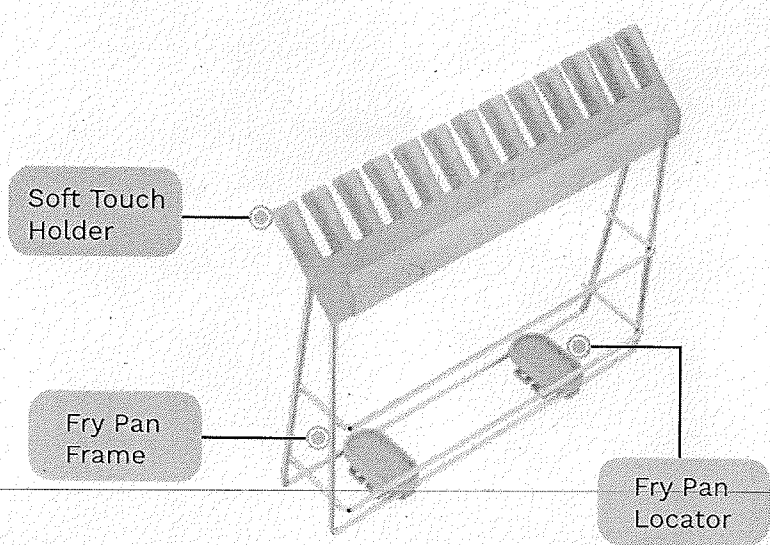

The SKIDO Fry Pan Organizer clamps the pan-handles in its flexible soft touch holder while storing them in the drawer.

Fry Pan Organizer consists of 1 frame, 1 soft touch holder and 2 locators. This set is available in two sizes **15** for 38cm & 43cm drawers and **19** for 48cm & 53cm drawers.

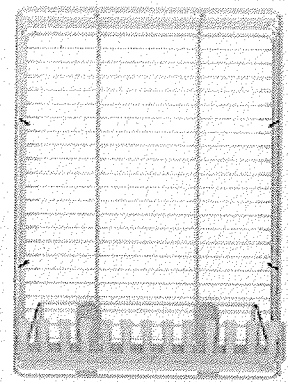

38cm  
Drawer | 4277

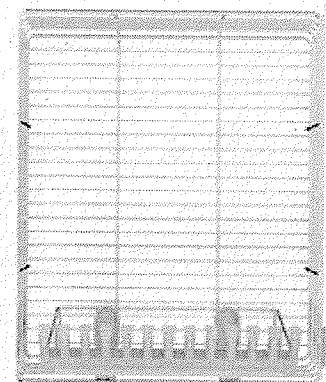

43cm  
Drawer | 4277

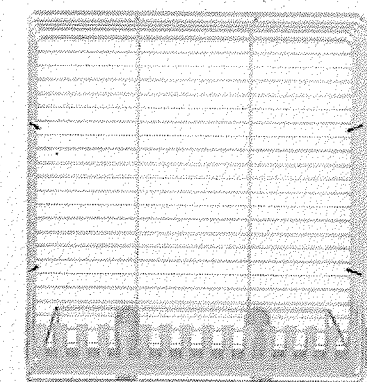

48cm  
Drawer | 4278

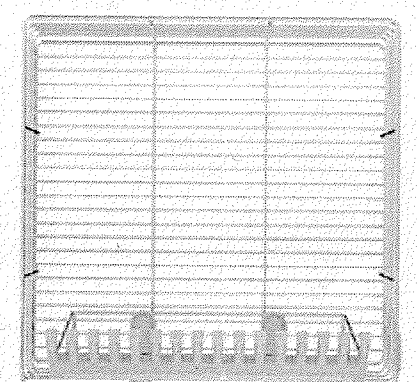

53cm  
Drawer | 4278